

SERIE 300

COMFORT AND DESIGN

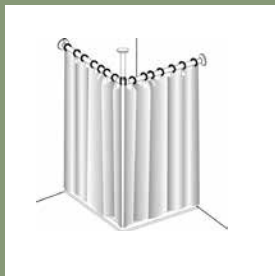

INDICE SERIE 300
INHALT SERIE 300
INDEX SERIE 300
INDICE SERIE 300

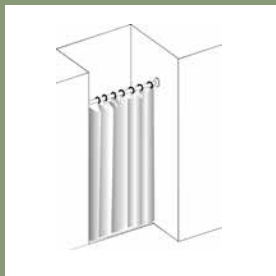
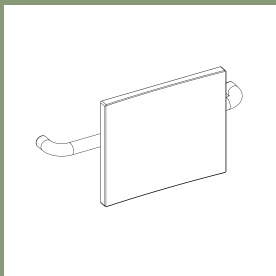
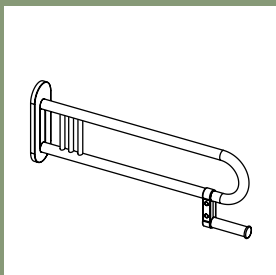
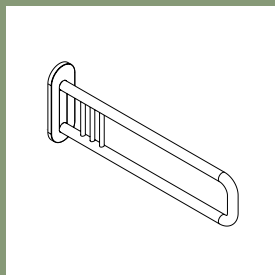
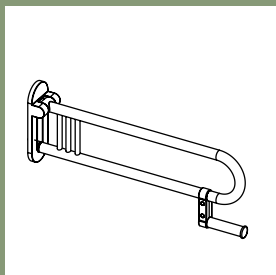
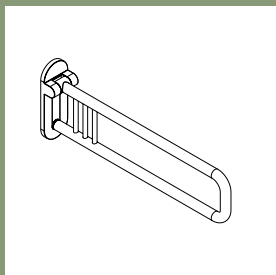
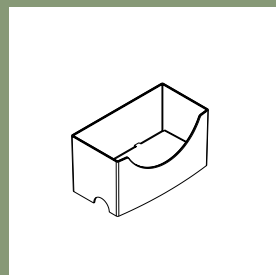
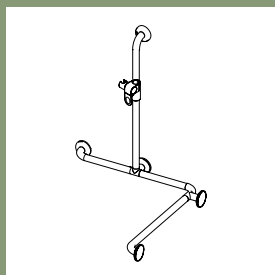
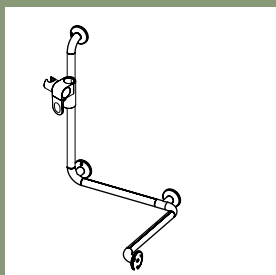
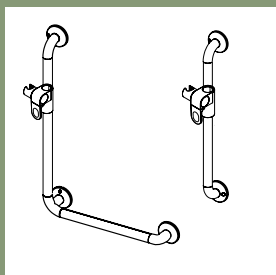
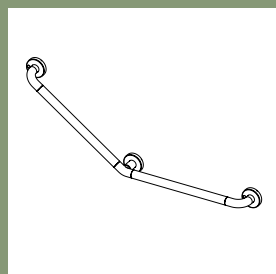
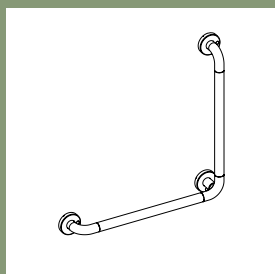
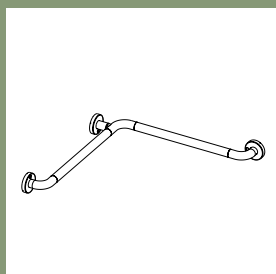
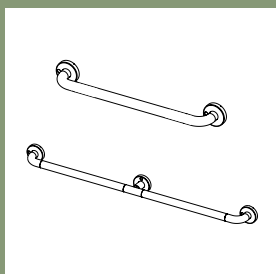
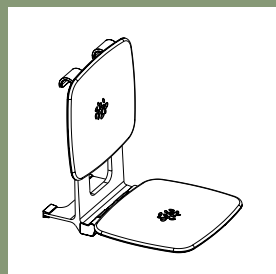
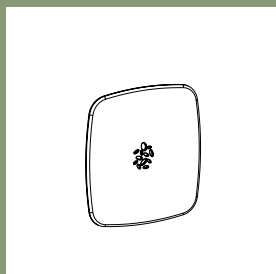
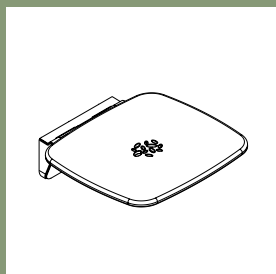



SERIE 300 - SISTEMA DI SEDILI E MANIGLIONI

Un disegno aggiornato e moderno, massima funzionalità, materiali di alta qualità e un sistema modulare: queste sono le eccezionali caratteristiche del sistema di maniglioni e sedili della serie 300. L'intero sistema è testato dall'ente TÜV con portate massime differenti e rispetta le normative per prodotti medicali CE EWG 93/42. Il sistema di sedili della serie 300 è stato sviluppato in collaborazione con il rinomato studio Talocci Design ed è composto da un esclusivo sedile ribaltabile, uno sgabello e un sedile agganciabile nelle varianti di colori differenti (bianco, cromo/bianco e cromo/grigio). Il sistema di maniglioni della serie 300 STEEL consiste di acciaio Inox spazzolato ed è disponibile in superficie satinato, applicabile soprattutto nel settore pubblico. Questo sistema di maniglioni è stato completato con il maniglione di sostegno e l'appoggio ribaltabile dalla forma classica e moderna, sviluppato in collaborazione allo studio Talocci Design.

SERIE 300 - SITZ- UND GRIFFSYSTEM

Modernes zeitgemäßes Design, absolute Funktionalität, hochwertige Materialien und modulares Baukastensystem – das sind die herausragenden Merkmale des Sitz- und Griffsystems der Serie 300. Das gesamte System ist mit verschiedenen Belastbarkeiten TÜV getestet und entspricht den Richtlinien für Medizinprodukte CE EWG 93/42. Das Sitzsystem Serie 300 wurde in Zusammenarbeit mit dem bekannten Designstudio Talocci entwickelt und setzt sich aus einem exklusiven Duschklappsitz, einem Badhocker und einem Einhängesitz in verschiedenen Farbvarianten (weiß, chrom/weiß und chrom/grau) zusammen. Das Griffsystem Serie 300 STEEL besteht aus gebürstetem Edelstahl und ist in der Farbvariante als satinierte Oberfläche, einsetzbar vor allem im öffentlichen Bereich verfügbar. Abgerundet wird dieses Programm durch den Klapp- und Stützgriff, das in Zusammenarbeit mit dem Designstudio Talocci in einer zeitlosen Form und höchsten Funktionalität entwickelt wurde.

SERIE 300 - SEAT AND GRAB BAR SYSTEM

A modern up-to-date design, absolute functionality, high-quality materials and modular construction system - those are the outstanding characteristics of the seat and handle system of the series 300. The whole system is TÜV tested with different maximum load-bearing capacities and corresponds to the standards for medicine products CE EWG 93/42. The seat system of the series 300 was developed in co-operation with the renowned design studio Talocci and is composed of an exclusive shower seat, a bath stool and a hanging seat in different colour variants (white, chrome/white and chrome/grey). The handle system of the series 300 STEEL consists of brushed stainless steel silver and is available with satin surface, applicable particularly in public areas. This handle system is rounded off by the folding and support handle, which was developed in co-operation with the Design studio Talocci in a classic form and highest functionality.

SERIE 300 - SISTEMA DE ASIENTOS Y ASIDEROS

Un diseño hasta la fecha moderno, materiales de alta calidad, funcionalidad absoluta y un sistema modular de la construcción - ésas son las características excepcionales del sistema de asientos y de asideros de la serie 300. El sistema entero es TÜV probado con diversas pruebas de calidad máximas y corresponde a los estándares para los productos de la medicina CE EWG 93/42. El sistema de asientos de la serie 300 fue desarrollado en cooperación con el estudio Talocci Design y se compone de un exclusivo asiento móvil para ducha, un taburete y un asiento colgado en diversas variantes de color (blanco, cromo/blanco y cromo/gris). El sistema de asideros de la serie 300 STEEL consiste en el acero inoxidable cepillado y está disponible en superficie satinado, aplicables para el público. Este sistema de asidero es completado por el asidero móvil y el asidero de apoyo, que fueron desarrollados en cooperación con el estudio Talocci Design en una forma clásica y una funcionalidad más alta.

SERIE 300 SD



Cromo/Grigio Chrom/Grau Chrome/Grey Cromo/Gris	Grigio Grau Grey Gris	Bianco Weiß White Blanco	Cromo/Bianco Chrom/Weiss Chrome/White Cromo/Blanco
05	17	31	69

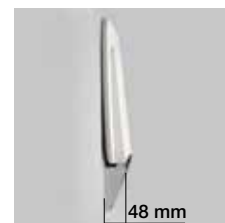

Descrizione articolo Artikelbezeichnung Model description Descripción artículo	Articolo Artikel Model Código	Misure Maße Sizes Medidas mm				
		A	B	C	D	
<p>Sedile ribaltabile Duschklappsitz Shower seat Asiento móvil para ducha</p>	3020 SD 05 PM	330	355	370	105	
	3020 SD 31 PM	330	355	370	105	
	3020 SD 69 PM	330	355	370	105	
<p>Schienale Rückenlehne Backrest Respaldo</p>	ZH 0085 17 PM	330	355			92,00
	ZH 0085 31 PM	330	355			88,00

Il sedile ribaltabile della serie 300 è stato sviluppato e testato secondo le più severe norme TÜV e CE. I materiali consistono soprattutto di alluminio e ABS di alta qualità – un'ingegnosa tecnica a cerniera garantisce la portata eccellente di 160 kg e nella versione chiusa è garantito massimo spazio per la doccia. Il sedile ribaltabile è disponibile in tre varianti di colori ed è stato sviluppato in collaborazione con lo studio Talocci Design.

Der Duschklappsitz der Serie 300 wurde nach höchsten TÜV und CE Richtlinien entwickelt und getestet. Die Materialien bestehen vorwiegend aus Aluminium und hochwertigem Kunststoff - eine ausgeklügelte Scharniertechnik gewährleistet exzellente Belastbarkeit von 160 kg und in der aufgeklappten Version wird ein maximaler Duschbereich gewährleistet. Der Duschklappsitz ist in drei Farbvarianten verfügbar und wurde vom bekannten italienischen Designstudio Talocci mitentwickelt.

The shower seat of the series 300 was developed and tested to the latest TÜV and CE guidelines. The materials mainly consist of aluminium and high-quality plastic – the ingenious hinge technology ensures excellent maximum stress of 160 kg and ensures a maximum shower area in the turned up position. The shower seat is available in three different colour variants and was developed in co-operation with the renowned design studio Talocci.

El asiento móvil para ducha de la serie 300 fue probado según los estándares más elevados de TÜV y CE. Los materiales consisten en aluminio y plástico de alta calidad - la tecnología ingeniosa de la bisagra asegura la tensión máxima de 160 kg y asegura un área máxima en la ducha por su forma delgada. El asiento móvil para ducha está disponible en tres variantes de color y fue desarrollado en cooperación con el estudio Talocci Design.

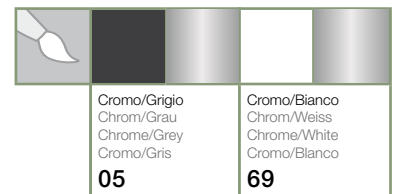

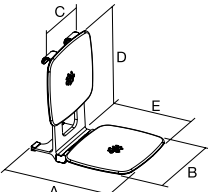
Descrizione articolo Artikelbezeichnung Model description Descripción artículo	Articolo Artikel Model Código	Misure Maße Sizes Medidas mm				
		A	B	C	D	E
 <p>Sedile agganciabile a maniglione* Einhängesitz für Griffsystem* Hanging seat for grab bar system* Asiento colgado por el sistema de asideros*</p>	3001 EP 05 PM	490	355	240	380-420	375
	3001 EP 69 PM	490	355	240	380-420	375

Il sedile appeso a barra è un prodotto ideale che unisce la sicurezza, il disegno e la comodità e rappresenta un mobiliario attraente, specialmente nella zona sanitaria privata e di hotellerie. Questo sedile appeso a barra può essere usato con tutti i sistemi di maniglioni, che hanno un diametro massimo di 34 mm - inoltre la registrazione semplice verticale di 4 cm accerta un'applicazione versatile.

Der Einhängesitz ist ein ideales Produkt, das Sicherheit, Design und Komfort vereint und stellt einen attraktiven Einrichtungsgegenstand, vor allem im privaten Sanitärbereich und der Hotellerie dar. Dieser Einhängesitz kann bei allen gängigen Griffsystemen, die einen Durchmesser von maximal 34 mm aufweisen, eingesetzt werden – weiters gewährleistet die einfache Höhenverstellung von 4 cm eine vielseitige Anwendung.

The hanging seat is an ideal product that combines security, design and comfort and represents an attractive furnishing, particularly in the private sanitary area and hotellerie. This hanging seat can be used with all usual handle systems, which have a diameter of maximally 34 mm, - further the simple vertical adjustment of 4 cm ensures a versatile application.

El asiento colgante es un producto ideal que une la seguridad, el diseño y la comodidad convirtiéndolo en un artículo atractivo, especialmente en la zona sanitaria privada y hotellerie. Este asiento suspendido en una barra puede ser utilizado con todos los sistemas de asideros, que ostenten en un diámetro de máximo 34 mm. Además el ajuste vertical simple asegura una aplicación versátil.

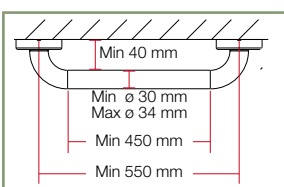

* **Produkt wird ohne Haltegriff geliefert**
Prodotto viene fornito senza maniglione
Product is delivered without grab bar
El producto se entrega sin asidero

SERIE 300 SH



05	31	69
Cromo/Grigio Chrom/Grau Chrome/Grey Cromo/Gris	Bianco Weiß White Blanco	Cromo/Bianco Chrom/Weiss Chrome/White Cromo/Blanco
RAL 9010		



Descrizione articolo Artikelbezeichnung Model description Descripción artículo	Articolo Artikel Model Código	Misure Maße Sizes Medidas mm			
		A	B	C	D
<p>Sgabello Badhocker Bathstool Taburete alto</p>	3001 SH 05 PM	355	425	320	440
	3001 SH 31 PM	355	425	320	440
	3001 SH 69 PM	355	425	320	440

Lo sgabello è omologato TÜV con una portata di 160 kg e rispetta le normative dell'UE per prodotti medicali CE EWG 93/42 – raggiunge massima stabilità tramite sostegni trasversali continui e collegati. Per il montaggio semplice e la facilità di pulizia, lo sgabello è molto facile da usare. Un design attuale e moderno, massima funzionalità e materiali di alta qualità caratterizzano questa serie.

Der Badhocker ist TÜV getestet mit einer Belastbarkeit von 160 kg und entspricht den EU Richtlinien für Medizinprodukte CE EWG 93/42 - er erreicht höchste Stabilität durch durchgehend verbundene Querstreben. Der Badhocker ist durch die einfache Montage und die Reinigungsfreundlichkeit äußerst benutzerfreundlich gestaltet. Modernes zeitgemäßes Design, absolute Funktionalität, hochwertige Materialien zeichnen diese Serie aus.

The bath stool is TÜV approved with a maximum load-bearing capacity of 160 kg and corresponds to the EU standards for medical products CE EWG 93/42 - excellent stability by continuous connected strut. The bath stool is really user-friendly through the simple assembly and the simplicity to clean. Modern design, absolute functionality and high-quality materials characterise this series.

El taburete alto ha sido probado por TÜV con una capacidad de carga máxima de 160 kg y corresponde a los estándares de la UE para los productos de medicina CE EWG 93/42 - estabilidad más alta por el puntal conectado continuo. El taburete del baño es realmente de uso fácil con un montaje simple y fácil limpieza. Un diseño hasta la fecha moderno, materiales de alta calidad y funcionalidad absoluta caracterizan esta serie.

SERIE 300 SG

SISTEMA DI MANIGLIONI
GRIFFSYSTEM
GRAB BAR SYSTEM
SISTEMA DE ASIDEROS



SERIE 300 STEEL SG

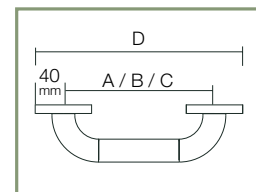

Descrizione articolo Artikelbezeichnung Model description Descripción artículo	Articolo Artikel Model Código	Misure Maße Sizes Medidas mm			
		A	B	C	D
<p>Maniglione Wandhaltegriff Holding handle Asidero fijo</p>	3001 SG 01 PM	250			330
	3002 SG 01 PM	450			530
	3003 SG 01 PM	550			630
	3004 SG 01 PM	650			730
<p>Corrimano a parete Wandhandlauf Wall handrail Barra de seguridad de pared</p>	3005 SG 01 PM	1050			1130
	3006 SG 01 PM	1150			1230
	3007 SG 01 PM	1250			1330
<p>Maniglione 145° reversibile Wandhaltegriff 145° reversibel Wall handle 145° reversible Asidero fijo 145° reversible</p>	3010 SG 01 PM	580	480		
	3011 SG 01 PM	680	480		
	3012 SG 01 PM	680	580		
<p>Maniglione 90° reversibile Wandhaltegriff 90° reversibel Wall handle 90° reversible Asidero fijo 90° reversible</p>	3015 SG 01 PM	600	450		
	3016 SG 01 PM	700	450		
	3017 SG 01 PM	700	550		
	3018 SG 01 PM	800	600		
<p>Sostegno angolare con supporto verticale Wandhaltegriff mit Senkrechtstütze Holding handle with vertical support Asidero fijo de pared con soporte vertical</p>	3020 SG 01 PM	450	560	525	
	3021 SG 01 PM	450	560	775	
<p>Corrimano singolo per doccia Duschhandlauf einfach Single shower handrail Barra de seguridad simple</p>	3025 SG 01 PM	660	675		
	3026 SG 01 PM	760	775		
	3028 SG 01 PM	910	1075		
<p>Corrimano doppio per doccia Duschhandlauf doppelt Double shower handrail Barra de seguridad doble</p>	3030 SG 01 PM	660	1125		
	3031 SG 01 PM	760	1125		
	3032 SG 01 PM	910	1125		
<p>Mensola per maniglioni Ablage für Griffe Shelf for grab bars Estante para soporte</p>	0080 ZH 17 PM	107	205	110	
	0080 ZH 31 PM	107	205	110	





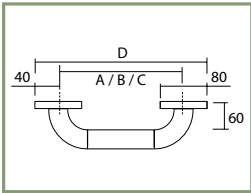

Il sistema di maniglioni della serie 300 STEEL è stato sviluppato in forma classica e massima funzionalità - è omologata secondo le normative TÜV e CE con una portata di 130 kg. Il sistema modulare e i sostegni trasversali continui e collegati permettono di offrire diverse varianti speciali con brevi tempi di consegna.

Das Griffsystem der Serie 300 STEEL wurde in einer zeitlosen Form und höchsten Funktionalität entwickelt und entspricht laut TÜV und CE Richtlinien einer Belastbarkeit von 130 kg. Durch das modulare System und durch innovative Verbindungstechnik können auch verschiedenste Sondermaßvarianten problemlos und mit kurzen Lieferzeiten angeboten werden.

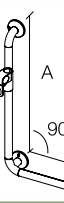
SERIE 300 STEEL SG

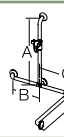

	RAL 9010		
	Satinato Satin Satinado	Grigio Grau Grey Gris	Bianco Weiß White Blanco
	01	17	31

Descrizione articolo Artikelbezeichnung Model description Descripción artículo	Articolo Artikel Model Código	Misure Maße Sizes Medidas mm				
		A	B	C	D	
 <p>Sostegno per doccia con saliscendi Haltegriff vertikal mit Brausehalter Holding handle with shower holder Soporte para brazo de ducha</p>	3050 SG 01 PM	800			880	
	3051 SG 01 PM	1000			1080	
 <p>Sostegno per doccia a 90° con saliscendi Haltegriff 90° mit Brausehalter Holding handle 90° with shower holder Soporte para brazo de ducha 90°</p>	3055 SG 01 PM	800	600			
	3056 SG 01 PM	1000	600			
	3057 SG 01 PM	1000	700			
	3058 SG 01 PM	1200	450			
	3059 SG 01 PM	1200	700			
 <p>Sostegno angolare con saliscendi Duschhandlauf mit Brausehalter Wall handrail with shower holder Asidero fijo de pared con soporte para brazo de ducha</p>	3060 SG 01 PM	800	560	525		
	3061 SG 01 PM	1000	560	525		
	3062 SG 01 PM	1000	760	775		
	3064 SG 01 PM	1200	760	775		
 <p>Sostegno angolo a T con saliscendi Duschhandlauf Ecke T-Form mit Brausehalter Handrail corner T-form with shower holder Barra de seguridad córner y T con brazo de ducha</p>	3070 SG 01 PM	1150	425	535	725	
	3071 SG 01 PM	1150	525	585	875	
	3072 SG 01 PM	1150	525	635	925	
 <p>Corrimano a T con saliscendi Handlauf T-Form mit Brausehalter Handrail T-form with shower holder Barra de seguridad T con brazo de ducha</p>	3110 SG 01 PM	1150	425	525		
 <p>Saliscendi sciolto Brausehalter lose Shower holder loose Soporte para ducha suelto</p> <p>Standard</p>	3001 BR 17 PM	Abbinabile a tutti i maniglioni - colore grigio Passend für alle Griffe - Farbe grau Suitable for all handles - colour grey Adaptable para todo asideros - colore gris				
 <p>Saliscendi sciolto Brausehalter lose Shower holder loose Soporte para ducha suelto</p>	3004 BR 17 PM	Abbinabile a tutti i maniglioni - colore grigio Passend für alle Griffe - Farbe grau Suitable for all handles - colour grey Adaptable para todo asideros - colore gris				

The Handle system of the series 300 STEEL was developed in a classic form and with absolute functionality and it is tested to the latest TÜV and CE guidelines with a maximum load-bearing capacity of 130 kg. Through the modular system and the innovative connection technique special measure variants can be easily offered with short delivery terms.

El sistema de asientos de la serie 300 STEEL fue desarrollado de forma clásica y con absoluta funcionalidad y probado según las normas más altas de TÜV y CE para la capacidad de carga máxima de 130 kg. Para el sistema modular con técnica innovadora de la conexión se pueden ofrecer fácilmente cortos plazos de entrega.

SERIE 300 STEEL SG



Satinato	Bianco	
Satiniert	Weiß	
Satin	White	
Satinado	Bianco	
01	31	



Descrizione articolo Artikelbezeichnung Model description Descripción artículo	Articolo Artikel Model Código	Misure Maße Sizes Medidas mm				
		A	B	C		
<p>Appoggio ribaltabile Klappgriff Folding handle Asidero móvil</p>	3045 SG 01 PM	650	280	100		
	3046 SG 01 PM	750	280	100		
	3047 SG 01 PM	850	280	100		
<p>Appoggio ribaltabile con portarotolo reversibile Klappgriff mit Papierrollenhalter reversibel Folding handle with paper holder reversibile Asidero móvil con portarrollos reversibile</p>	3245 SG 01 PM	650	280	100		
	3246 SG 01 PM	750	280	100		
	3247 SG 01 PM	850	280	100		
<p>Portarotolo di riserva Reserve Papierrollenhalter Additional paper holder Citapa de reserva</p>	0262 BG 01 PM	115	150			
<p>Tenda Duschvorhang Shower curtain Cortina ducha</p>	0050 VH 31 PM	850	640-850			
<p>Schienale per WC con maniglione Rückenlehne für WC mit Haltegriff Backrest for WC with handle Respaldo para WC con asidero</p>	3090 ZH 01 PM	355	300	550	582	
<p>Schienale per WC Rückenlehne für WC Backrest for WC Respaldo para WC</p>	3095 ZH 01 PM	355	300	80		

Ø 32/33/34 mm

SERIE 300 STEEL SG

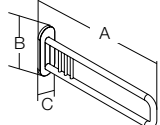
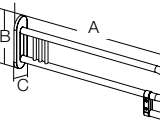
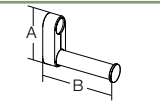
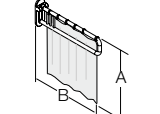

		
Satinato Satiniert Satin Satinado	Bianco Weiß White Blanco	
01	31	

Descrizione articolo Artikelbezeichnung Model description Descripción artículo	Articolo Artikel Model Código	Misure Maße Sizes Medidas mm					
		A	B	C			
 Maniglione di sostegno Stützgriff Support handle Asidero de apoyo	3040 SG 01 PM	650	280	100			
	3041 SG 01 PM	750	280	100			
	3042 SG 01 PM	850	280	100			
 Maniglione di sostegno con portarotolo reversibile Stützgriff mit Papierrollenhalter reversibel Support handle with paper holder reversible Asidero de apoyo con portarollos reversibile	3240 SG 01 PM	650	280	100			
	3241 SG 01 PM	750	280	100			
	3242 SG 01 PM	850	280	100			
 Portarotolo di riserva Reserve Papierrollenhalter Additional paper holder Citapa de reserva	0262 BG 01 PM	115	150				
 Tenda Duschvorhang Shower curtain Cortina ducha	0050 VH 31 PM	850	640-850				

Il maniglione di sostegno e ribaltabile sono in acciaio europeo spazzolato di alta qualità e sono disponibili in superficie opaca satinato, soprattutto per uso nel bagno privato. Sono stati sviluppati in collaborazione con lo studio Talocci Design e sono la simbiosi perfetta tra design moderno e tecnica sicura. La portata di 130 kg, l'uso di fissaggi coperti e l'assenza di spigoli pericolosi, garantiscono un uso sicuro e delle buone caratteristiche di manutenzione. Sono disponibili con e senza porta rotolo.

Der Stütz- und Klappgriff besteht aus hochwertigem, gebürstetem europäischen Edelstahl und ist in der Farbvariante satiniert mit matter Oberfläche vor allem für das private Bad verfügbar. Entwickelt wurden sie in Zusammenarbeit mit dem Designstudio Talocci Design und ist die perfekte Symbiose aus modernem Design und sicherer Technik. Die Belastbarkeit von 130 kg, die Verwendung von abgedeckten Befestigungen und Vermeidung von Stoßkanten gewährleisten eine sichere Benutzung und gute Pflegeeigenschaften. Verfügbar sind sie mit oder ohne Papierrollenhalter.

The support and folding handle consists of high quality, European, brushed stainless steel and are available in satin matt, mainly for application in the private sanitary area. The handles were developed in co-operation with the Design studio Talocci and is a perfect symbiosis between modern design and secure technology. The maximum load-bearing capacity of 130 kg, the use of covered fixings and curved edges ensure safe and easy use. They are available with or without paper holder.

El asidero de apoyo y móvil está fabricado en acero inoxidable de alta calidad, europeo, cepillado y está disponible en superficie mate para el uso en el área sanitaria privada. Fue desarrollado en cooperación con el estudio Talocci Design y es una simbiosis perfecta entre el diseño moderno y tecnología segura. La capacidad de carga máxima de 130kg y el uso de fijaciones cubiertas y la ausencia de esquinas peligrosas, garantizan un uso seguro y un buen mantenimiento. Es disponible con o sin el portarollos.

SERIE 300 VH + VN + VE + VU

TUBO CON TENDA DOCCIA
 DUSCHSTANGE MIT VORHANG
 TUBE WITH SHOWER CURTAIN
 BARRA CON CORTINA DE DUCHA

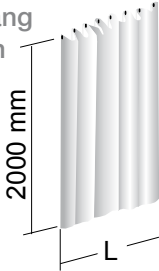
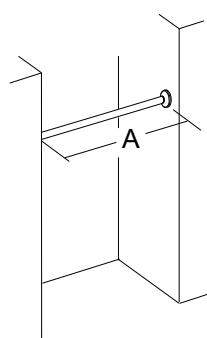
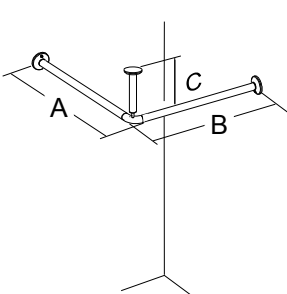
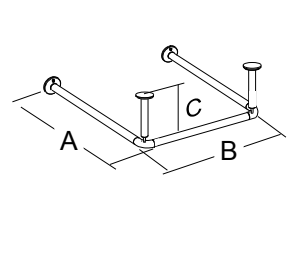
		Tende consigliate Passender Duschvorhang Suitable shower curtain Cortina aconsejable							
				0007 VH 31 PM L = 1200 mm	0010 VH 31 PM L = 1500 mm	0013 VH 31 PM L = 1800 mm	0019 VH 31 PM L = 2400 mm	0025 VH 31 PM L = 3000 mm	0031 VH 31 PM L = 3600 mm
Articolo Artikel Model Código									
Nicchia - Nische - Niche - Huecos		3004 VN 01 PM A = 900 mm Anelli - Ringe - hooks - aillas 8	1x						
		3005 VN 01 PM A = 1000 mm Anelli - Ringe - hooks - aillas 10		1x					
		3007 VN 01 PM A = 1200 mm Anelli - Ringe - hooks - aillas 10		1x					
		3010 VN 01 PM A = 1500 mm Anelli - Ringe - hooks - aillas 12			1x				
Angolo - Ecke - Corner - Angular	 C = 585 mm	3004 VE 01 PM A = 900 mm B = 900 mm Anelli - Ringe - hooks - aillas 16				1x			
		3005 VE 01 PM A = 1000 mm B = 1000 mm Anelli - Ringe - hooks - aillas 16				1x			
		3007 VE 01 PM A = 1200 mm B = 1200 mm Anelli - Ringe - hooks - aillas 20					1x		
		3010 VE 01 PM A = 1500 mm B = 1500 mm Anelli - Ringe - hooks - aillas 24						1x	
A "U" / "U"-Form / "U"-form / En "U"	 C = 585 mm	3004 VU 01 PM A = 900 mm B = 900 mm Anelli - Ringe - hooks - aillas 8 + 16	1x			1x			
		3005 VU 01 PM A = 1000 mm B = 1000 mm Anelli - Ringe - hooks - aillas 10 + 16		1x		1x			
		3007 VU 01 PM A = 1200 mm B = 1200 mm Anelli - Ringe - hooks - aillas 10 + 20		1x			1x		
		3010 VU 01 PM A = 1500 mm B = 1500 mm Anelli - Ringe - hooks - aillas 12 + 24			1x			1x	



Satinato Satiniert Satin Satinado	Bianco Weiß White Blanco	
01	31	

Descrizione articolo Artikelbezeichnung Model description Descripción artículo	Articolo Artikel Model Código	Misura piatto doccia Tassenmaß Tray size Medidas del plato mm		
		A	B	
<p>Tenda nicchia Duschvorhang Nische Shower curtain niche Cortina ducha forma de cavidad</p>	0007 VH 31 PM	900		
	0010 VH 31 PM	1000		
	0010 VH 31 PM	1200		
	0013 VH 31 PM	1500		
<p>Tenda angolo Duschvorhang Ecke Shower curtain corner Cortina ducha angular</p>	0019 VH 31 PM	900	900	
	0019 VH 31 PM	1000	1000	
	0025 VH 31 PM	1200	1200	
	0031 VH 31 PM	1500	1500	
<p>Tenda a "U" Duschvorhang "U"-Form Shower curtain "U"-form Cortina ducha en forma "U"</p>	0007 VH 31 PM + 0019 VH 31 PM	900	900	
	0010 VH 31 PM + 0019 VH 31 PM	1000	1000	
	0010 VH 31 PM + 0025 VH 31 PM	1200	1200	
	0013 VH 31 PM + 0031 VH 31 PM	1500	1500	
<p>Tubo reggitenda nicchia Duschstange Nische Shower curtain tube niche Barra cortina ducha forma de cavidad</p>	3004 VN 01 PM	900		
	3005 VN 01 PM	1000		
	3007 VN 01 PM	1200		
	3010 VN 01 PM	1500		
<p>Tubo reggitenda angolo Duschstange Ecke Shower curtain tube corner Barra ducha angular</p>	3004 VE 01 PM	900	900	
	3005 VE 01 PM	1000	1000	
	3007 VE 01 PM	1200	1200	
	3010 VE 01 PM	1500	1500	
<p>Tubo reggitenda a "U" Duschstange "U"-Form Shower curtain tube "U"-form Barra ducha en forma "U"</p>	3004 VU 01 PM	900	900	
	3005 VU 01 PM	1000	1000	
	3007 VU 01 PM	1200	1200	
	3010 VU 01 PM	1500	1500	